

CURRENT 1.0 Ampere
 VOLTAGE RANG 50 to 1000 Volts

RS1ABF THRU RS1MBF

FEATURES

- Plastic package has underwrites laboratory flammability Classification 94V-0
- Low profile surface mount package
- Built-in strain relief
- Fast switching for high efficiency
- Glass passivated chip junction
- High temperature soldering
- 250 /10 second at terminals

S M B F

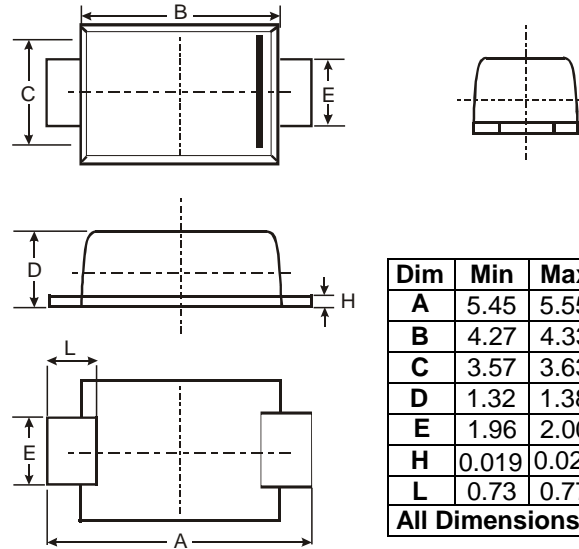

Dim	Min	Max	Typ
A	5.45	5.55	5.50
B	4.27	4.33	4.30
C	3.57	3.63	3.60
D	1.32	1.38	1.35
E	1.96	2.00	1.98
H	0.019	0.021	0.20
L	0.73	0.77	0.75
All Dimensions in mm			

MECHANICAL DATA

- Case: JEDED SMBF molded plastic over glass passivated chip
- Terminals: Solder plated, solderable per MIL-STD-750, method 2026
- Polarity: Color band denotes cathode end
- Weight: 0.002ounce, 0.09gram

MAXIMUM RATINGS & THERMAL CHARACTERISTICS

- Ratings at 25 ambient temperature unless otherwise specified

	SYMBOLS	RS1A	RS1B	RS1D	RS1G	RS1J	RS1K	RS1M	UNIT
Maximum Repetitive Peak Reverse Voltage	V_{RRM}	50	100	200	400	600	800	1000	Volts
Maximum RMS Voltage	V_{RMS}	35	70	140	280	420	560	700	Volts
Maximum DC Blocking Voltage	V_{DC}	50	100	200	400	600	800	1000	Volts
Maximum Average Forward Rectified Current $T_L=90$	$I_{F(AV)}$	1.0							Amps
Peak Forward Surge Current 8.3ms single half sine wave superimposed on rated load (JEDEC method) $T_L=90$	I_{FSM}	30							Amps
Typical Thermal Resistance (Note 1)	R_{JA}	105							/W
	R_{JL}	32							
Operating junction and Storage Temperature Range	T_J, T_{STG}	-55 to +150							

ELECTRICAL CHARACTERISTICS

	SYMBOLS	RS1A	RS1B	RS1D	RS1G	RS1J	RS1K	RS1M	UNIT	
Maximum Instantaneous Forward Voltage at 1.0A	V_F	1.30							Volts	
Maximum DC Reverse Current at rated DC Blocking Voltage	$T_A = 25$	5.0							μA	
	$T_A = 125$	50								
Typical Reverse Recovery Time at $I_F=0.5A, I_R=1.0A, I_{RR}=0.25A$	t_{rr}	150				250	500		ns	
Typical junction capacitance at 4.0V, 1MHz	C_J	30							7.0	pF

Notes:

- Thermal resistance from Junction to ambient and from junction to lead mounted on P.C.B. with 0.2x0.2" (5.0 x 5.0mm) copper pad areas.

CURRENT 1.0 Ampere
 VOLTAGE RANG 50 to 1000 Volts

RS1ABF THRU RS1MBF

RATING AND CHARACTERISTIC CURVES RS1A Thru RS1M

F1G.1-FORWARD CURRENT DERATING CURVE

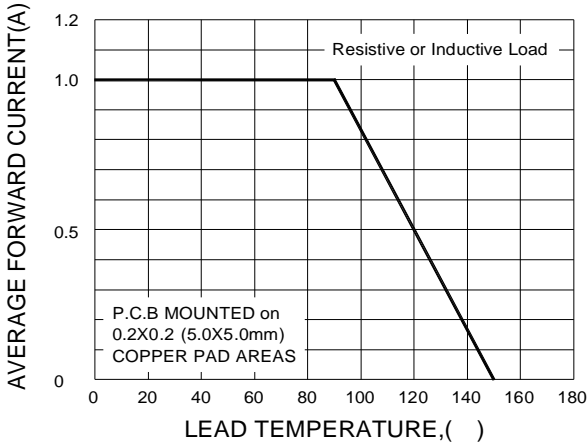

F1G.2-MAXIMUM NON-REPETITIVE PEAK FORWARD SURGE CURRENT

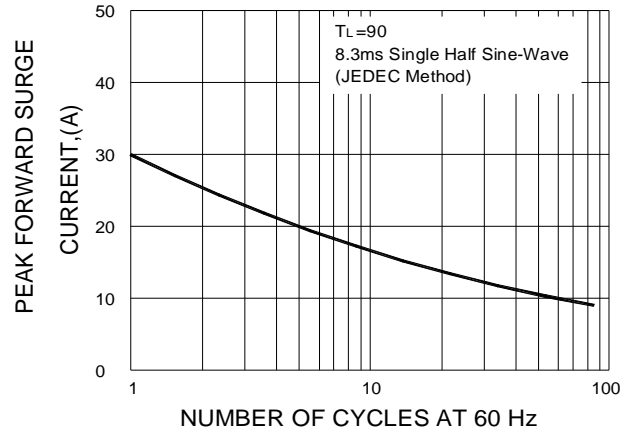

F1G.3-TYPICAL INSTANTANEOUS FORWARD CHARACTERISTICS

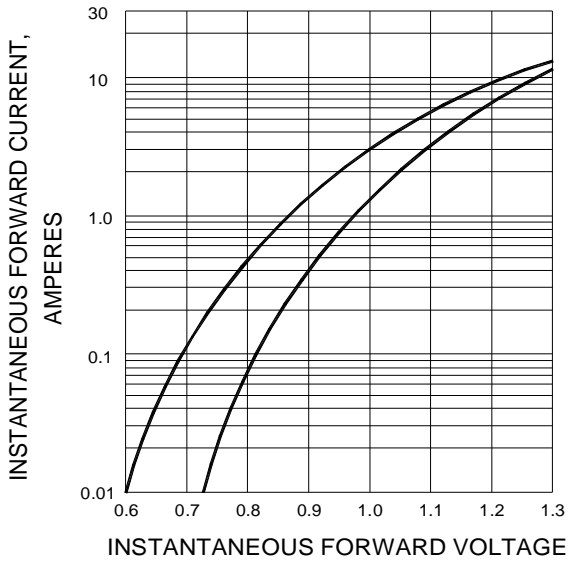

F1G.4-TYPICAL REVERSE CHARACTERISTICS

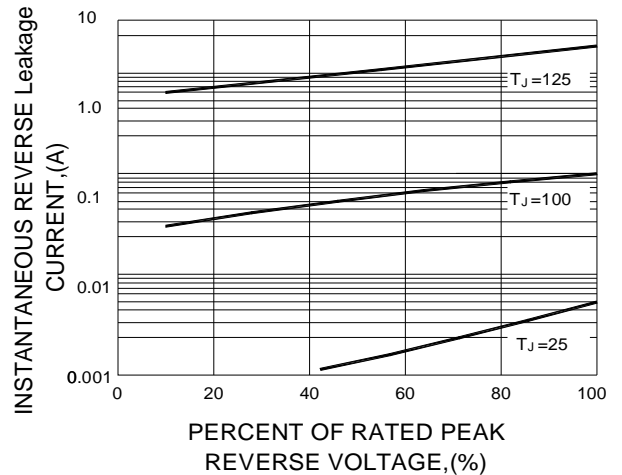

F1G.5-TYPICAL JUNCTION CAPACITANCE

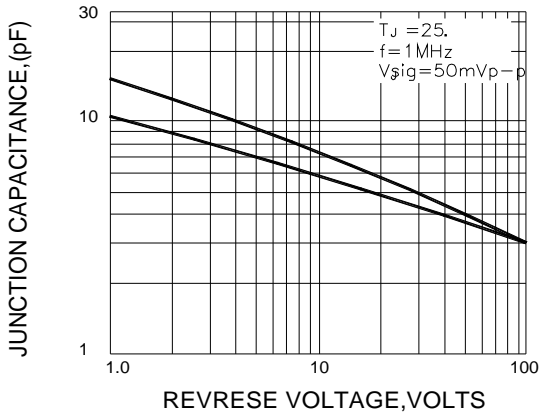

F1G.6-TYPICAL TRANSIENT THERMAL IMPEDANCE

